

NZH

**TRANSPORT
HYDRAULIC
SOLUTIONS**



HARSH®

**HARSH A5-D40 STABILISED
TIPPING GEAR**

Call NZH on 0800 22 55 69

www.nzh.co.nz

HARSH A5-D40 TIPPING GEAR

	Tipping Capacity (Tonne)	Body Length (mm)
A5	2.0	2500
A6	3.0	2500
B10	5.5	3000
C20	6.5	3300
D40	9.5	3500

Capacity and length are averages based on:

- Mount length providing 45° tipping angle.
- Diminishing load.
- 200mm tail hinge overhang.
- Maximum operating pressure.

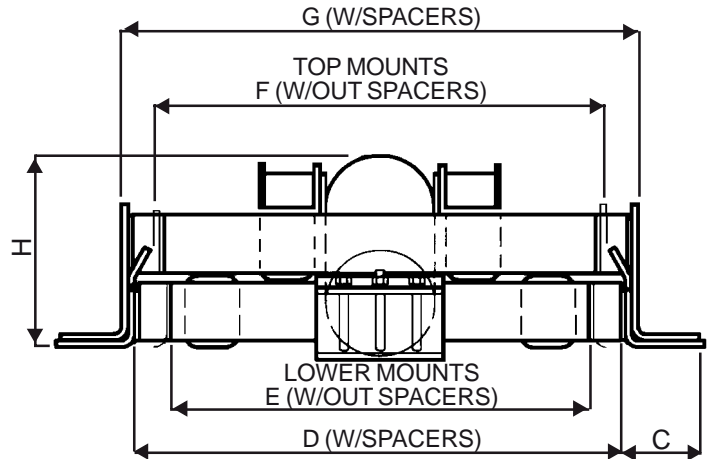
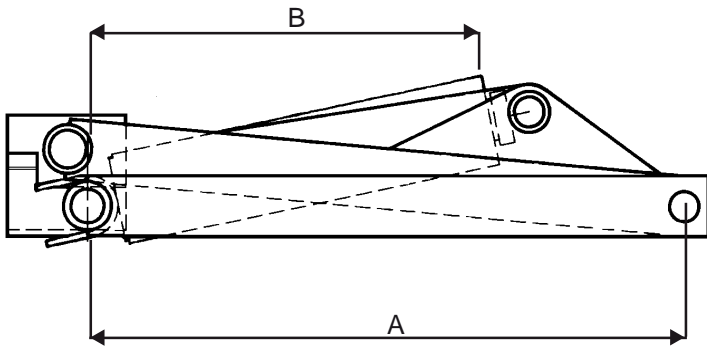

Features:

- ✓ Double acting cylinders.
- ✓ High polished hard chrome cylinders.
- ✓ Fast tipping cycle.

Benefits:

- ✓ Vehicle/body versatility.
- ✓ Dynamic stability in tough environments.
- ✓ Built and tested to last longer.
- ✓ Ease of maintenance.

DIMENSIONS

	A5	A6	B10	C20	D40
A	560	711	730	889	1019
B	370	N/A	489	587	672
C	N/A	N/A	197	197	197
D	N/A	N/A	690	690	690
E	362	438	605	605	605
F*	362	438	640	640	640
G	N/A	N/A	730	730	730
H	152	179	232	267	270

* This dimension is a minimum.

Note:

Dimension 'E' can be increased to reduce the amount of chassis flange overhang by pulling the chassis brackets outwards as required up to a maximum of 35mm a side or by utilising the spacers provided.