

NZH

TRANSPORT
HYDRAULIC
SOLUTIONS

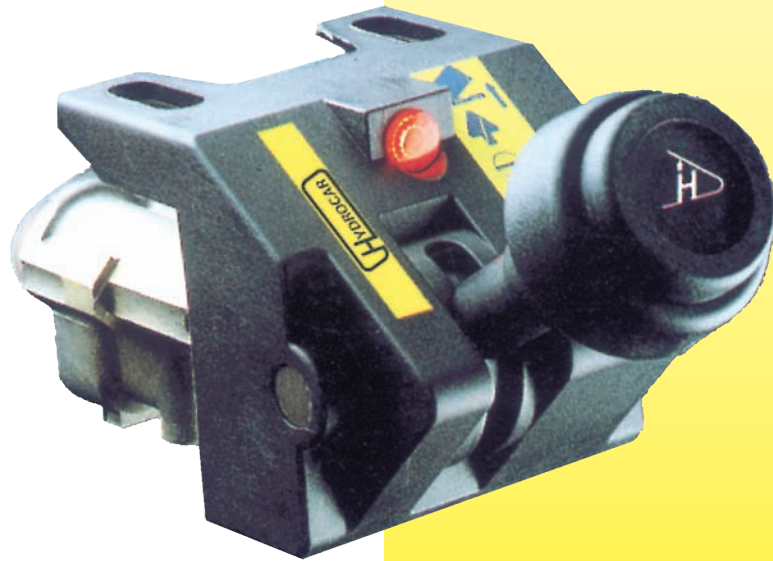

HYDROCAR

HYDROCAR ORIGINAL STYLE
CAB CONTROLS

Call NZH on 0800 22 55 69

www.nzh.co.nz

HYDROCAR CAB CONTROLS

CP1S/DPZ SINGLE SHIFT CAB CONTROL

This circuit with an open centre to the cylinder allows proportional lowering speed settings of the tipper body.

The single level controls:

- Body tipping when in position "1".
- Body will hold in position "0".
- Proportional lowering speed setting when in position "2".

NB Proportional capability when combined with Proportional Valve.

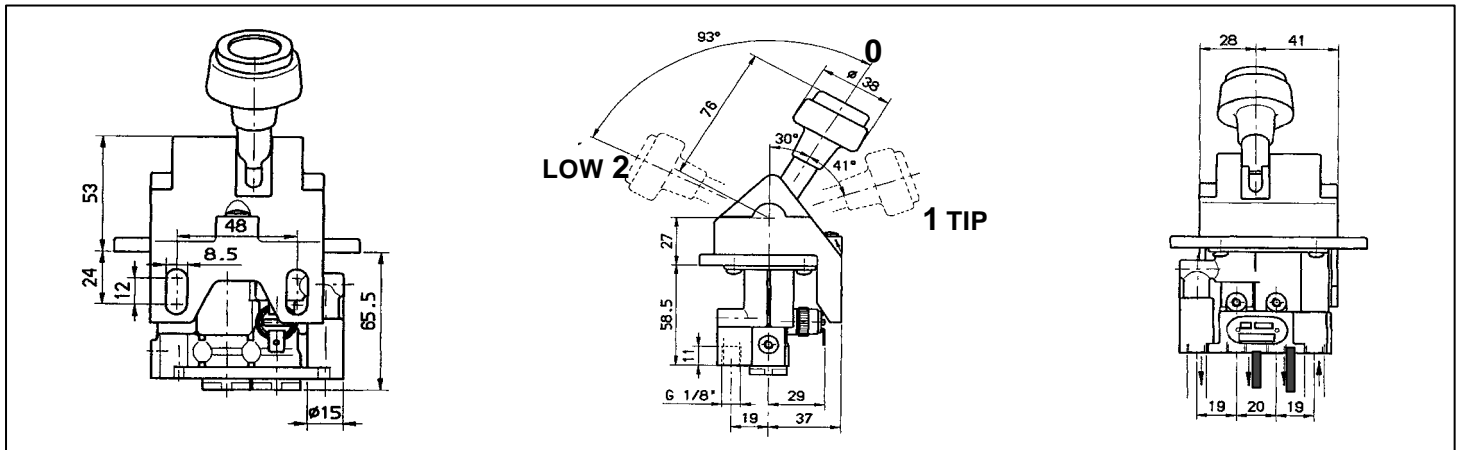

CP2S/DPZ DOUBLE SHIFT CAB CONTROL

This circuit with an open centre to the cylinder allows proportional lowering speed settings of the tipper body.

The first shift can control:

- PTO engagement when in position "A".
- PTO disengagement when in position "B".

The second shift can control:

- Body tipping when in position "1".
- Body will hold in position "0".
- Proportional lowering speed setting when in position "2".

NB Proportional capability when combined with Proportional Valve.

