

**NZH**

TRANSPORT  
HYDRAULIC  
SOLUTIONS



35 GALLON HYDRAULIC  
RESERVOIR

Call NZH on 0800 22 55 69  
[www.nzh.co.nz](http://www.nzh.co.nz)

# 35 GALLON HYDRAULIC RESERVOIR

## Features:

- ✓ Tank top filter
- ✓ Filler breather
- ✓ Level temperature sight glass
- ✓ Filter blockage indicator
- ✓ Anti-Oil foaming return line diffuser standard
- ✓ Come complete with brackets, straps and mounting bolts
- ✓ Won't crack like steel
- ✓ Greater impact resistance than steel
- ✓ Extremely lightweight (only 30 lbs)
- ✓ Contaminate-free from slag, rust or oxidation

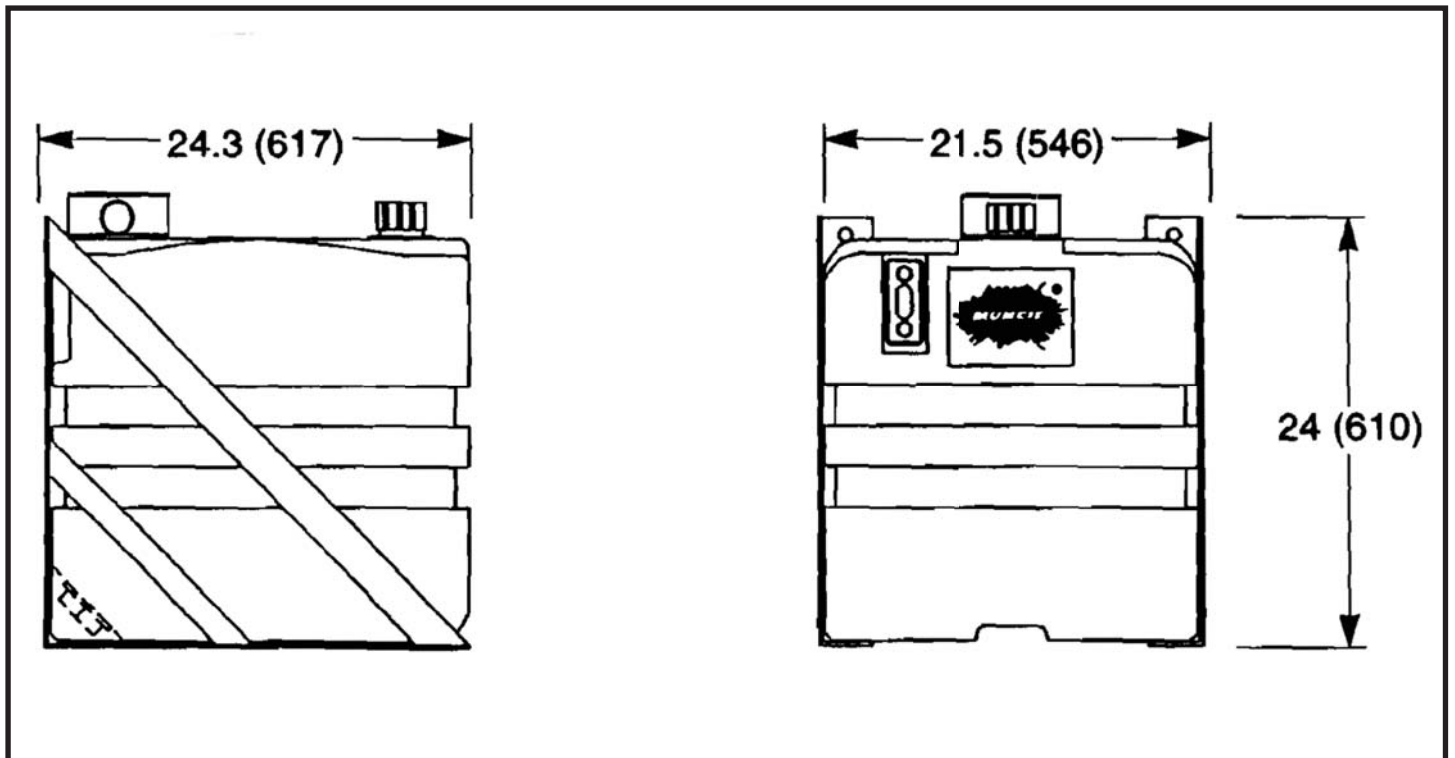

## Other sizes available

Other sizes include a 50 gallon side mount and 50 and 70 gallon uprights which contain many of the same features as our 35 gallon reservoir.